

# TAO MOTOR BOULDER-B1 OWNER'S MANUAL



# **TABLE OF CONTENTS**

Warranty & Maintenance Information.....	4
Tools Required: .....	5
Specifications .....	6
Post Delivery Inspection (PDI).....	7
Pre-Ride Inspection.....	9
Assembly .....	11
Battery Activation .....	14
The 7-Step Process to Activate an Motorcycle Battery .....	15
Appendix .....	18
Maintenance Schedule .....	18
Engine Oil .....	19
Change Engine Oil .....	20
Changing Air Filter.....	21
Spark Plug.....	22
Drive Chain.....	23
Adjust Drive Chain.....	24
Parking Brake .....	26
Engine Stop Lanyard Cord and Remote .....	27
Control Layout.....	29
Speed Limiter .....	30
Choke Lever.....	31
Fuel Tank Capacity .....	32
Fuel Cock/ Fuel Valve .....	33
Tires.....	34
Tire Wear Limit.....	34
Starting Engine (Warm vs. Cold) .....	35
Breaking in the Engine .....	35
Parking .....	36
Accessories and Modifications.....	36
Rear Cargo Rack .....	36
Gear Selector Lever.....	37
Throttle Cable .....	37

Front Brake Lever .....	38
Front Brake Lever Adjustment .....	38
Hydraulic Rear Brake.....	39
Engine Idle Adjustment.....	40
Adjusting Suspension Spring Preload.....	40

Veloz PowerSports Inc.



- 1: Protective clothing
- 2: Protective Goggles
- 3: Protective Gloves
- 4: Protective Boots
- 5: Protective Helmet



Do not operate after or while consuming alcohol or drugs.

The operator's performance capability is reduced by the influence of alcohol or drugs.

Consuming alcohol or drugs could seriously affect your judgment, cause you to react more slowly, and affect your balance and perception.



**WARNING**

Never consume alcohol or drugs before or while driving this ATV. You increase your chance of an accident.

### WARNING

**This is an Automatic ATV that should only be ridden on off-road dirt trails only!**

**Avoid riding on asphalt, concrete, sand, etc.**

**This ATV is meant for beginners and is not designed for riding up and down steep hills.**

## **Warranty & Maintenance Information**

*As the vehicle owner you are responsible for the vehicle maintenance. These responsibilities included but are not limited to periodic maintenance, pre- storage maintenance, pre-ride inspections to be performed before each ride.*

*After riding the vehicle, you are responsible for cleaning, drying, lubing, and the necessary adjustments to maintain proper vehicle maintenance. You are responsible for keeping records of these maintenance and services and will be requested to provide copies of the receipts for these maintenance services along with photos or video of the vehicle when submitting a claim requesting coverage under the limited parts warranty.*

*Claims without verifiable proof of maintenance or professional PDI will be denied.*

*Our products do require some assembly. If you choose to assemble your unit you accept all liability for the unit and will void your warranty. In order not to void your warranty, you must have a licensed mechanic motorcycle assemble your unit. Be sure to save the receipt or any paperwork proving the work(s) carried out by the licensed mechanic.*

*Do not operate the machine until it has been completely inspected by a certified mechanic. Have the licensed mechanic check that all bolts and components are assembled properly. We offer assembled units but under no circumstances takes responsibility for the safety of the product.*

*The limited parts warranty covers defective parts due to manufacture error only and excludes damages caused by anything other than a defective part.*

*All parts must be returned for inspection.*

*For the 1-year engine warranty the engine must be returned to our warehouse for inspection to determine eligibility and accompanied with all maintenance records and receipts.*

## Tools Required:

- 13mm Socket and Wrench
- 10mm Socket
- 24mm Socket
- #2 Phillip's Head Screwdriver
- Fuel Stabilizer (Recommended)



You will also need some supplies for the initial set up such as:

- Blue Loctite
- Premium Gasoline 91 or 93 Octane rating
- Quart of quality, Standard Type, 15W-40 oil (Castrol, Valvoline, etc.)
- Battery Tender / Charger of 3 Amps or less

**\*\*Recommended but not required.**

**\*\*Recommended** to have LOCTITE on major nuts and bolts including the Brake Caliper, Rotors, Front and Rear axle, Handlebar hardware, and Exhaust hardware, and any other major hardware. **\*\***



## **Specifications**

Fuel Tank.....	.60 Gal (2.3L)
Engine Oil .....	SAE 15W40
Climbing .....	≥12°
Acceleration Noise Level .....	≤80dB
Recommended Tire Pressure .....	5 PSI

### CHASSIS

Brake Front/Rear .....	Front Drums, Rear Disc Brake
Brake .....	Hand Brake, Foot Brake
Front tire .....	14.5x7-6
Rear tire.....	14.5x7-6
Max Front tire Pressure .....	10 PSI
Max Rear tire Pressure .....	10 PSI
Minimum Front tire Pressure .....	2.0 PSI
Minimum Rear tire Pressure .....	2.0 PSI
Weight GW.....	205 lbs

### DIMENSIONS

Overall Length.....	45.7 in. (1,160mm)
Overall Width .....	28 in. (711mm)
Overall Height.....	33.3 in (845mm)
Seat Height .....	24.8 in. (629mm)

### ENGINE

Type.....	Single-Cylinder Four-Stroke, Air-Cooled, Automatic Centrifugal Clutch
Displacement.....	107CC
Bore X Stroke.....	52.4 mm x 49.5 mm
Idle Speed .....	1500±150 RPM
Start Mode .....	Electric start
Ignition Method .....	CDI
Spark Plug Gap .....	0.06~0.085mm
Transfer Method .....	Chain Drive
Compression Ratio.....	9.5:1
Valve Clearance .....	I-0.03~ E-0.05mm
Spark Plug .....	NST/ A7RTC NGK / CR6HSA

## **Post Delivery Inspection (PDI)**

“PDI” refers to the “Post Delivery Inspection” process you are going to carry out after you have done the basic assembly. The following is a set of recommended guidelines for you to follow as you complete your own “PDI” and setup for your PRODUCT before use.

### **Step 1**

Completely inspect all nuts, bolts, and fasteners to ensure that all factory assembled parts are in fact correctly assembled and secure. It is recommended that you remove the bolts, fastener listed below and apply Loctite to the threads to prevent them from rattle loose. Failure to follow this recommendation can lead to loss damage parts and even injury

Brake rotor mounting bolts

Rear sprocket mounting bolts

Exhaust manifold nuts and bolts

Brake caliper mounting bolts

All Engine mounting bolts

### **Step 2**

Visually inspect all wiring and wiring connections to ensure that all connections are secure and intact with no loose or disconnected wiring.

1. We suggest you unplug the cdi box and make sure all the wires are fully pressed into the connector and retract the CDI
2. Check the two wires going to the ignition coil and if they feel a little loose remove the wire and crimp the connector lightly with a pair of pliers and reattach them to the ignition coil in the same order they were removed.
3. Inspect all the wires and connectors for the stator to the main harness. These are the wires that are located on the left side of the engine and attach to the main harness.

**Step 3** inspect all front-end steering and suspension components, ensure all fasteners are tight and secure. Position the handlebars facing straight forward and stand in front on the vehicle and inspect the front alignment. If the alignment is not perfectly aligned Within  $\frac{1}{8}$  it is highly recommended you adjust the alignment to avoid safety issues and premature tire wear.

**Step 4** Before starting always check the engine oil before each ride. Refer to starting instructions for this step.

**Step 5** Run the engine to normal operating temperature and adjust the carburetor idle speed screw as required to ensure that the engine runs smoothly. See carb adjustment section for this step

**Step 6** The bike is now ready for the “break in period”. Ride the bike gently for the first 25 hours of operation to allow mating parts to wear into each other. Speed up and gear down slowly. Never hold a

constant speed for an extended period. Most important!!! Do not drive the bike at high speed, full out speed is not recommended until the engine is broken in.

**Step 7** After assembling the vehicle drain and replace the shipping oil with the recommended motor oil before starting the engine. After riding your new vehicle for 3 to 5 hours change the lubricating engine oil. Use the recommended oil for your bike. Usually 15W-40 Motorcycle/ATV Oil and adjust the chain, as the chain will begin to stretch with use and should be inspected before every ride and adjusted as needed.

Veloz PowerSports Inc.

# Pre-Ride Inspection

Inspect the ATV prior to each use to ensure it is in a safe operating condition. Always follow the inspections, procedures and schedules described in the Owner's Manual.



Failure to inspect or maintain the vehicle properly increases the possibility of an accident or equipment failure. Do not operate the vehicle if any problem is discovered. If a problem cannot be corrected by the procedures described in this manual, have the vehicle inspected by a Tao Motor dealer.

ITEM	ROUTINE
Fuel (91 octane min.)	<ul style="list-style-type: none"> <li>• Check fuel level in fuel tank, and add recommended fuel if necessary.</li> <li>• Add Fuel Stabilizer if using ethanol fuel.</li> <li>• Check fuel line for leakage. Correct if necessary.</li> </ul>
Engine Oil	<ul style="list-style-type: none"> <li>• Check oil level in engine, and add recommended oil to specified level if necessary.</li> <li>• Check ATV for oil leakage. Correct if necessary.</li> </ul>
Front Brake	<ul style="list-style-type: none"> <li>• Check operation, and correct if necessary.</li> <li>• Lubricate cable if necessary.</li> <li>• Check lever free play, and adjust if necessary.</li> </ul>
Rear Brake	<ul style="list-style-type: none"> <li>• Check operation, and correct if necessary.</li> </ul>
Throttle Lever	<ul style="list-style-type: none"> <li>• Make sure that operation is smooth. Lubricate cable and lever housing if necessary.</li> <li>• Check lever free play, and adjust if necessary.</li> </ul>
Control Cables	<ul style="list-style-type: none"> <li>• Make sure that operation is smooth. Lubricate if necessary.</li> </ul>
Drive Chain	<ul style="list-style-type: none"> <li>• Check chain slack, and adjust if necessary.</li> <li>• Check chain condition. Lubricate if necessary.</li> </ul>
Wheels & Tires	<ul style="list-style-type: none"> <li>• Check wheel condition, and replace if damaged.</li> <li>• Check tire condition and tread depth. Replace if necessary.</li> <li>• Check air pressure. Keep tires inflated per the PSI specified in manual.</li> </ul>
Brake Levers	<ul style="list-style-type: none"> <li>• Make sure that operation is smooth. Lubricate lever pivoting points if necessary.</li> </ul>
Chassis Fasteners	<ul style="list-style-type: none"> <li>• Make sure that all nuts, bolts and screws are properly tightened.</li> </ul>
Instruments & Switches	<ul style="list-style-type: none"> <li>• Check operation, and correct if necessary.</li> </ul>

## FUEL

Make sure that there is sufficient fuel in the tank. Never overfill fuel tank.

## ENGINE OIL

Make sure that the engine oil is at the specified type. Follow manual's specifications, keep filled as needed, but never overfill.

**AIR FILTER:** The air filter has an oiled foam element. It must be inspected daily or more frequently when riding in dusty conditions. It should be cleaned and re-lubed whenever it appears dry or visible dirt is present. Refer to page 52 for instructions and recommended lubricants. A dry or dirty air filter can allow dirt to enter the engine. Engine damage due to improper air filter maintenance is not covered under warranty.

**DRIVE CHAIN:** The drive chain should be inspected daily. If it appears dry or has excessive slack, it must be adjusted and lubricated. Refer to the Owner's Manual for instructions and recommended lubricants.

## FRONT & REAR BRAKES

### BRAKE LEVER

Check for too much free play in brake levers. If there is too much free play or if the brake levers require adjusting, have your Tao Motor dealer check the brake levers and brakes and have the brakes adjusted to the driver.

### BRAKE OPERATION

Test the brakes at slow speed after starting out to make sure they are working properly. If the brakes do not provide proper braking performance, check the brake shoes/pads for wear.

### THROTTLE LEVER

Check the operation of the throttle lever. It must open smoothly and spring back to the idle position when released. If throttle is not operating properly DO NOT START ENGINE. Have a Tao Motor dealer correct the issue before operating this ATV.

### SWITCHES

Check to ensure all switches are working properly before starting the engine.

### DRIVE CHAIN

Check the condition of the drive chain and check the drive chain slack. Lubricate and adjust the drive chain as necessary.

## Assembly

1. The handlebars should rest between the two brackets and line up with the holes at the base of the handlebar. Adjust handlebar position while securing tightly with 10mm socket.

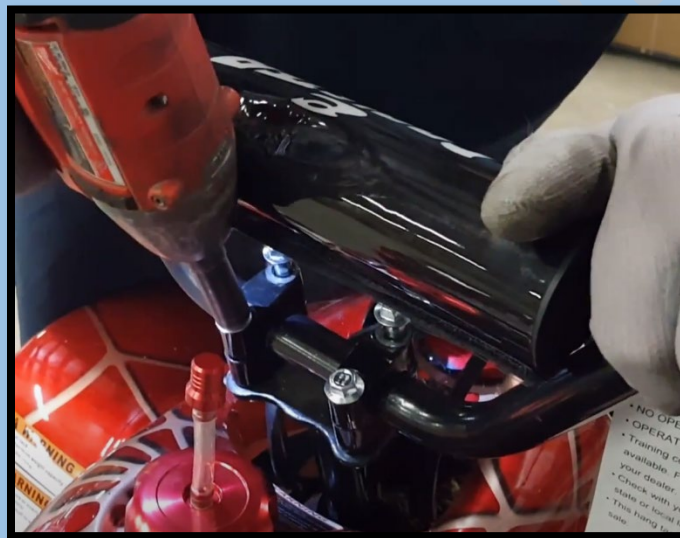

2. When installing the rear tire, make sure the treads orientated with the arrows pointed forward. Put the tire on the axle. Then put on your washer, dust cap washer, and castle nut, secure.



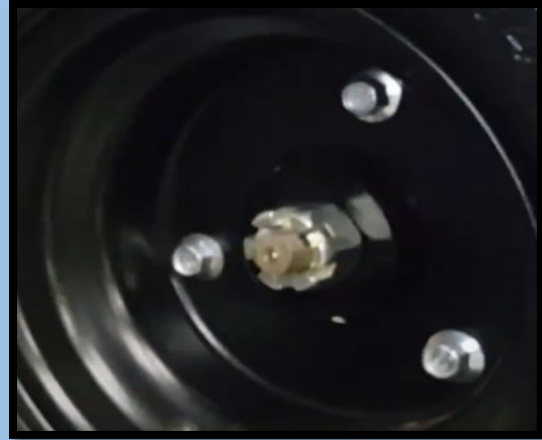

3. Same rules apply for the front tire with the treads facing forward. Put on the front tire by aligning it with the three bolts on the axle and secure with nuts using 13mm socket.



4. Install the racks by tightening 4 bolts on the underside of the vehicle (2 on each side) using 10mm socket.

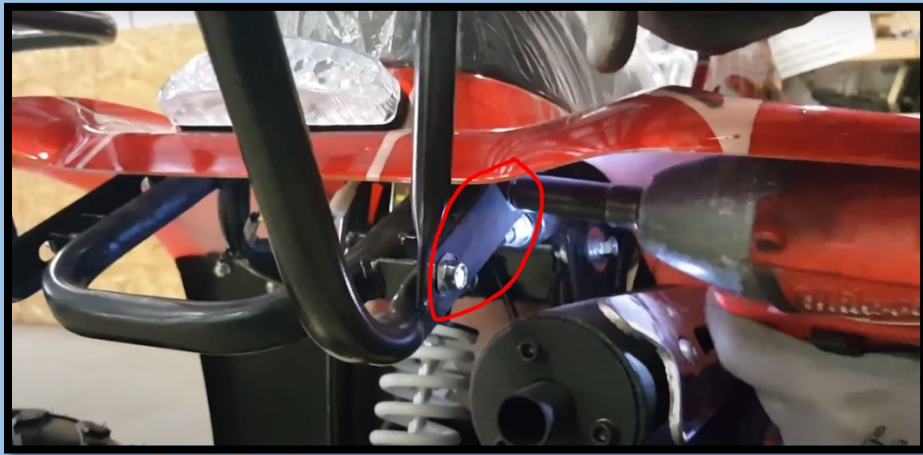
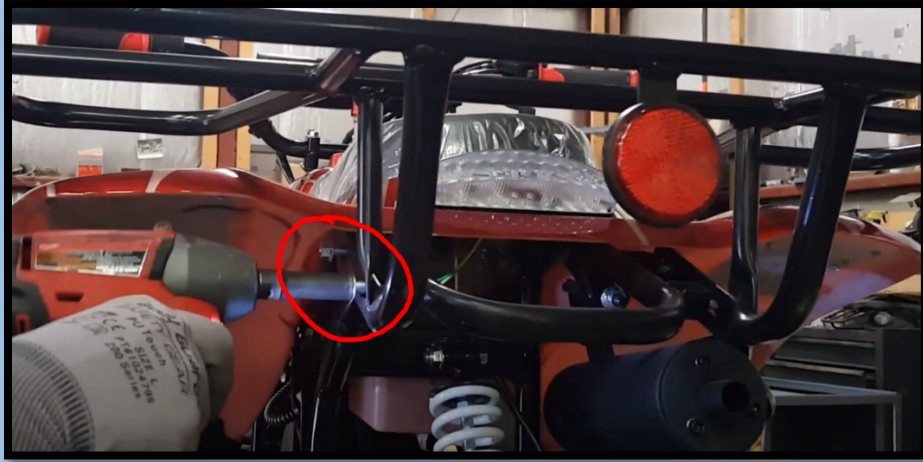

5. Install front bumper by tightening the nuts and bolts. The top 2 use bolts AND nuts, the bottom 2 use ONLY the bolt.

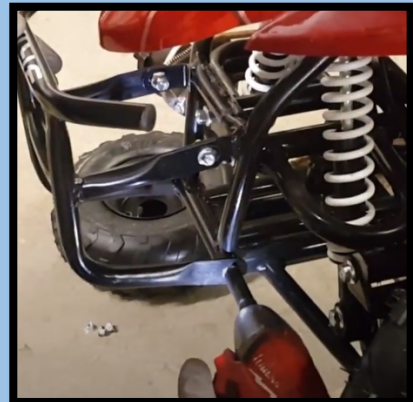
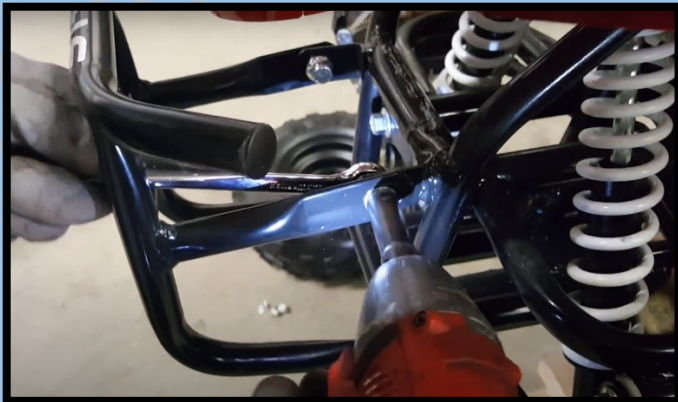

## Battery Activation

Activating a Motorcycle/ATV Battery is a simple, 7-step process that nearly any rider or mechanic can follow with success. Remember to always practice caution when handling batteries and activation equipment.

Motorcycle batteries are shipped with the electrolyte stored in a plastic container. The battery is filled with electrolyte from the container when it is ready to be activated. Once a battery is unsealed, it should be activated, charged, before it is installed. **WARNING:** If you do not follow the proper activation and charging instruction prior to use of the battery can result in damage to the battery.

Always read the precautions and instructions on the electrolyte container before handling and filling your battery.

***Do not smoke when activating a battery or handling battery acid. Always wear plastic gloves and protective eyewear.***

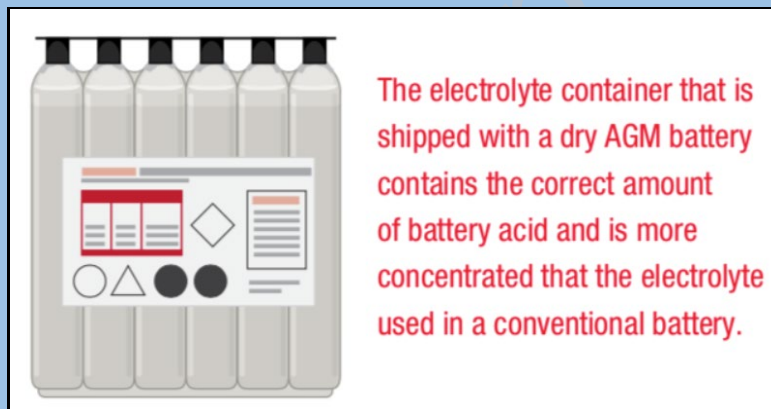

## The 7-Step Process to Activate an Motorcycle Battery

1. The battery must be out of the vehicle and sitting on a level surface.
2. Remove the electrolyte container from the plastic storage bag. Remove the strip of caps and set it aside as it will be necessary later in this process. When filling your Motorcycle battery use only the dedicated acid container that comes with the battery as it contains the proper amount of electrolyte. This is important to service life and battery performance. **Do not pierce or otherwise open the foil seals on the electrolyte container. Do not attempt to separate the individual electrolyte containers.**

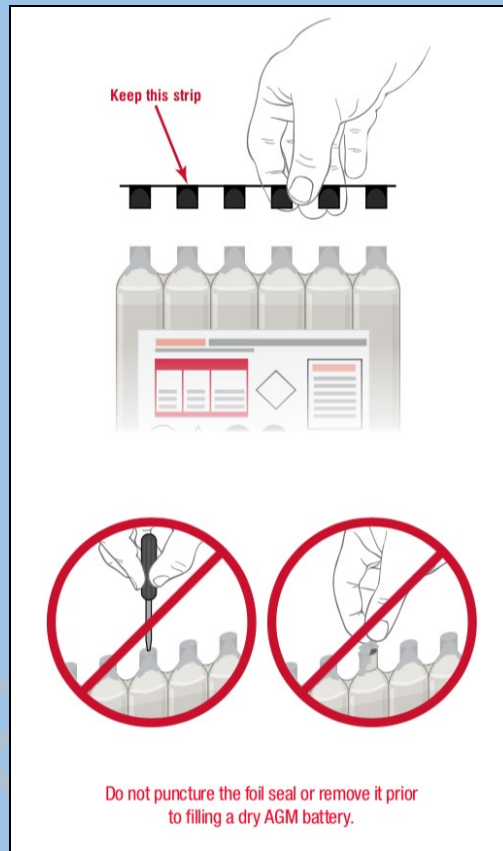

3. Place the electrolyte container with the foil seals face-down into the cell filler ports on the battery. Hold the container level and push down to break the foil seals. Electrolyte will start to flow into the battery and air bubbles will be seen inside the container. **Do not tilt the electrolyte container.**
4. Check the electrolyte flow. **Keep the container in place for 20 minutes or longer until it empties completely.** If no air bubbles are coming up from the filler ports or if the container cells haven't emptied completely after 20 minutes, then tap the container and/or battery case gently a few times to cause the electrolyte to flow into the battery. Do not remove the acid container from the battery until it is completely empty. The battery requires the entire electrolyte from the container for proper operation.

- Carefully remove the empty electrolyte container from the battery. Fully insert the strip of sealing caps (previously removed from the electrolyte container) into the battery filling ports. Make sure the strip of caps is fully inserted and flush with the top of the battery. Insert the caps by hand, do not use a hammer or excessive force.

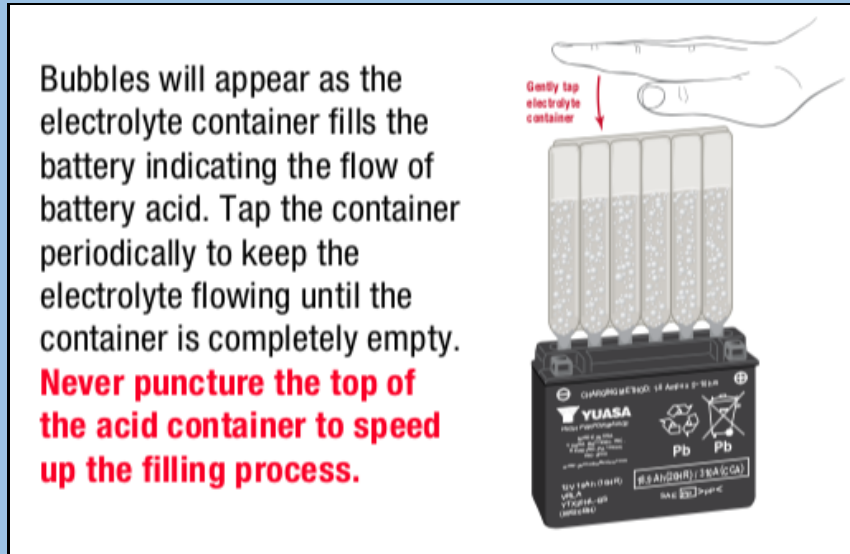

**Never remove the strip of caps or add water or electrolyte to the battery during its service life.**

- For batteries with ratings of less than 18 AH, let the battery stand for 20 to 60 minutes.** For batteries with higher AH ratings or having the **High-Performance rating (designated by an "H" in the part number/name)**, allow the battery to stand for 1 to 2 hours. Batteries have amp hour (AH) printed on the front of the battery case. The stand or rest period allows the electrolyte to permeate into the plates for optimum performance.
- VERY IMPORTANT DO NOT SKIP THIS STEP!!! IF you do not have the proper battery charger to charge the battery at slow 3amps then you will need to take the battery to your local auto parts store or motorcycle dealer and request they charge it for you at no more than 3 Amps. Newly activated batteries require an initial charge.** After adding electrolyte, a new battery is approximately 75-80% charged. After the "stand" period described in step 6, charge the battery to bring it to a full state-of-charge. The battery charger used for initial charging should be able to charge at a slow no more than 3 amps for a motorcycle battery. All **Yuasa battery chargers** can reach this minimum voltage and initializing/activating an AGM battery.

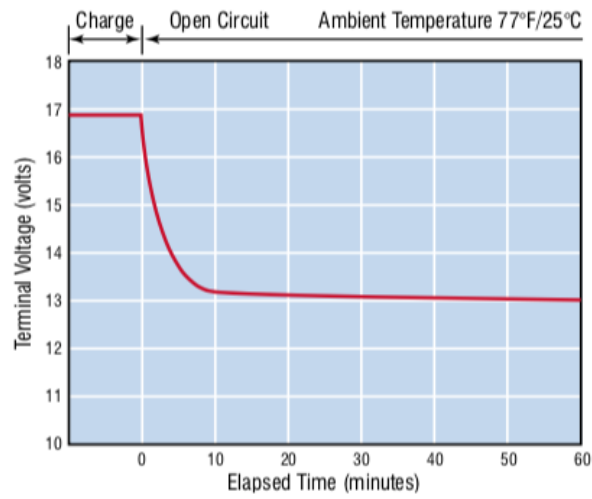

During the initial charging period, battery voltage may reach over 16 volts. Open circuit voltage should be checked after the battery is allowed to stand between 1 and 2 hours.

# Appendix

## Maintenance Schedule

•For safety reasons, it is recommended that service be performed by a dealer.

ITEMS	NOTE	Each ride or about 2.5 hours	Every 3 ride or about 10 hours	Every 6 ride or about 20 hours	Every 9 ride or about 30 hours	Every 12 ride or about 40.0 hours
Throttle Inspection		X				
Air Filter	1	C				
Crankcase Breather		X				
Spark Plug		X				
Valve Clearance	4			X		
Engine Oil	3	X				
Engine Idle Speed		X				
Drive Chain		X,L		R		
Drive Chain Slider		X				
Drive Chain Roller		X				
Drive Sprocket		X				
Driven Sprocket		X				
Brake Fluid	2	X				
Brake Pads Wear		X				
Brake System		X				
Clutch System		X				
Control Cables		X,L				
Exhaust Pipe / Muffler		X				
Suspension		X				
Swingarm / Shock Linkage			L			
Nuts, Bolts, Fasteners		X				
Wheels / Tires		X				
Steering Head Bearings					X	

X: Inspect and clean, adjust, lubricate, or replace, if necessary

C: Clean

A: Adjust

L: Lubricate

R: Replace

### Note:

1. For mileage higher than what is specified in the chart, the maintenance should be repeated at the same interval listed.

2. More frequent maintenance is required if the vehicle is used in dusty areas or in rain.

3. More frequent replacement is required if the vehicle is subjected to severe use, such as heavy load operation, long trips or operation in rain.

## Engine Oil

The engine oil level should be checked before each ride. In addition, always follow the maintenance schedule for oil changes as shown in the maintenance schedule.

### NOTE

Your new vehicle's engine comes with shipping oil, shipping oil must be changed before the engine is started for the first time. Please see specification chart for recommended oil type.

### To check the engine oil level

1. Place the ATV on a level surface.
2. Check the engine oil level on a cold engine.
3. Remove the engine oil filler cap, and then wipe the engine oil dipstick off with a clean rag.
4. Slowly thread the dipstick back in the filler hole, and then remove it again to check the oil level.
5. If the engine oil is at or below the minimum level mark, add sufficient oil of the recommended type to raise it to the correct level.

**NOTICE:** Be sure the engine oil is at the correct level, otherwise engine damage may result.

6. Check the O-ring for damage, and replace it if necessary.
7. Insert the dipstick into the oil filler hole, and then tighten the engine oil filler cap.

### TIP

If the engine was started before checking the oil level, be sure to warm up the engine sufficiently, and then wait at least ten minutes until the oil settles for an accurate reading.

### TIP

The engine oil dip stick is located on the right side of the ATV behind the right foot rest.

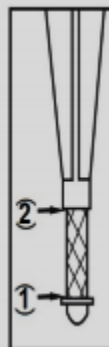
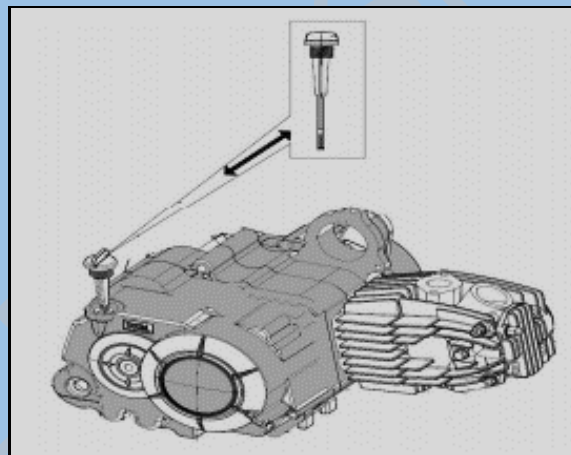

### ⚠ WARNING

**Only add engine oil into the dipstick filler hole. Never pour engine oil anywhere else other than dipstick filler hole.**

1. Minimum Oil Level Mark
2. Maximum Oil Level Mark

## Change Engine Oil

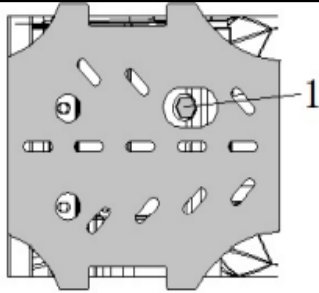

1. Engine Oil Drain Plug (17mm)

1. Place the ATV on a level surface.
2. Place an oil pan under the engine to collect the used oil.
3. Remove the engine oil filler cap, and then remove the engine oil drain bolt to drain the oil from the crankcase.
4. Reinstall O-ring and drain plug to the specified torque.(14 Nm / 10 ft/lbs).
5. Refill engine with specified amount of the recommended engine oil.  
Recommended engine oil is SAE 15W40 and oil capacity is 0.8 US qt. or 0.8 liters.
6. Start the engine, and then let it idle for a few minutes .
7. Turn off engine and check engine dip stick for correct engine oil level .

NOTICE: When removing the engine oil drain bolt the 0-ring may fall out. Take care not to lose these parts.

NOTICE: Before installing the engine oil drain bolt, be sure to install the 0-ring, and then engine drain bolt.

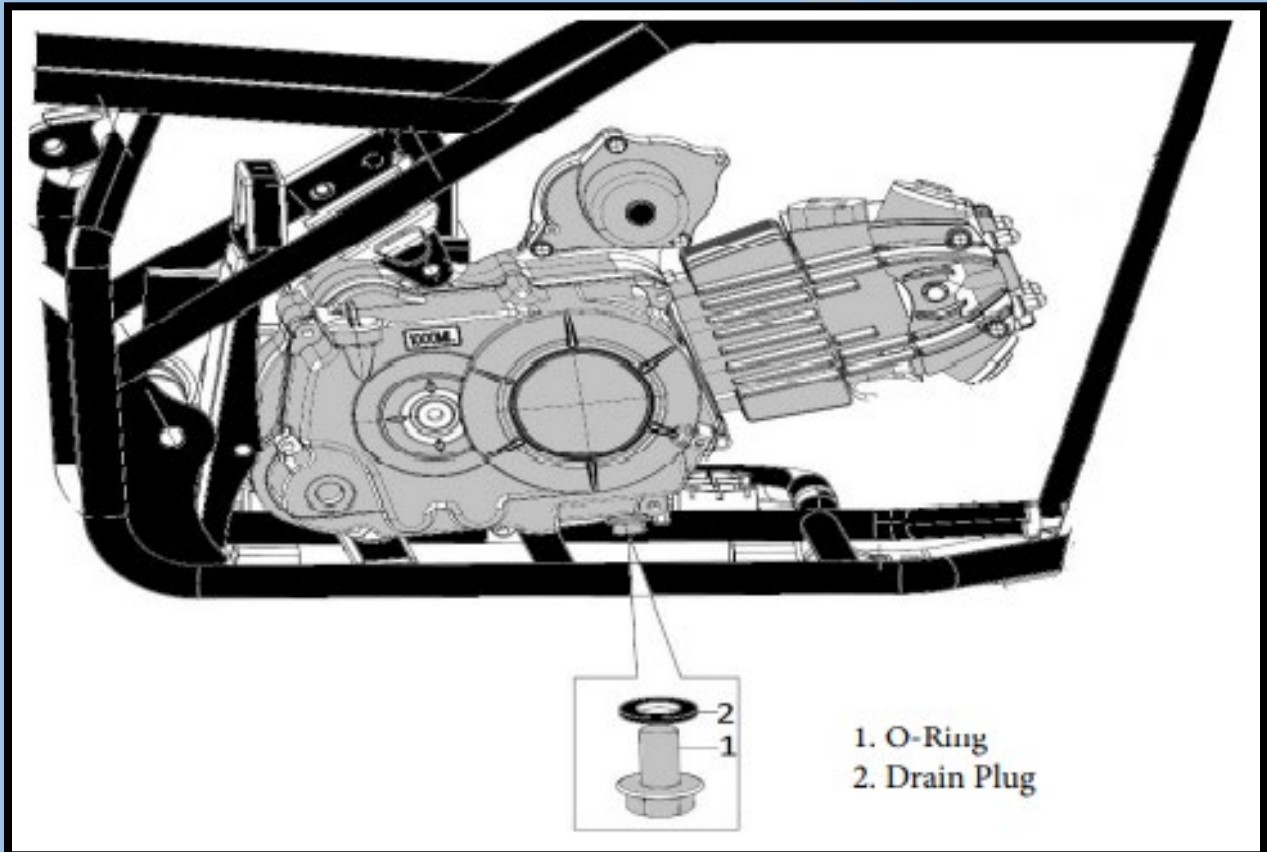

1. O-Ring
2. Drain Plug

## Changing Air Filter

The air filter element should be serviced at the intervals specified in the periodic maintenance and lubrication chart. Clean and replace as needed. Clean and replace air filter more frequently if used in dusty or dirty areas.

### **⚠ WARNING**

Never use low-flash-point solvents or gasoline to clean the air filter element because the engine could catch fire or explode.

### **NOTICE**

Do not twist the air filter element when squeezing it. Make sure that the air filter element is properly seated in the air filter case. Never operate the engine with the air filter element removed. This will allow unfiltered air to enter the engine, causing rapid engine wear and possible engine damage. Additionally, operation without the air filter element will affect carburetor jetting with subsequent poor performance and possible engine overheating.

The air filter element should be cleaned every 20-40 hours. It should be cleaned and lubricated more often if the ATV is operated in extremely dusty areas. When servicing the air filter element, be sure to check the air inlet of the air filter case for obstructions.

1. Park the ATV on a level surface.
2. Remove the seat.
3. Remove the air filter cover by removing the two phillips screws .
4. Remove the air filter element and clean it with foam air filter cleaning solution.
5. Squeeze the excess solvent out of the air filter element and let it dry.
6. Check the air filter element and replace it if damaged.
7. Apply foam air filter oil or other quality foam air filter oil to the **foam element**.
8. Insert the air filter element into the air filter housing .
9. Install the air filter cover and the two phillips screws.
10. Install the seat.

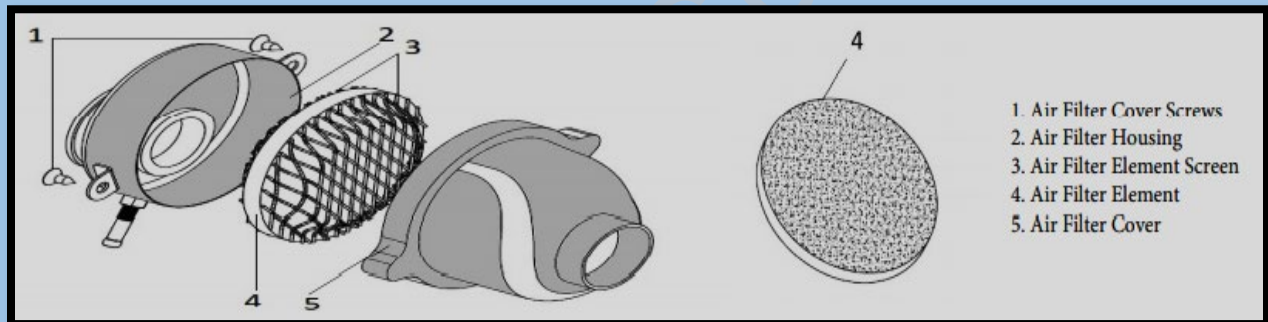

## Spark Plug

### Checking the spark plug

The spark plug is an important engine component, which is easy to check. The spark plug should be removed and checked in accordance with the periodic maintenance and lubrication chart.

### To remove the spark plug

1. Remove the spark plug cap.
2. Remove the spark plug as shown, with the spark plug wrench included in the owner's tool kit.
3. Turn the spark wrench counterclockwise to loosen and remove the spark plug.

### To check the spark plug

1. Check that the porcelain insulator around the center electrode of the spark plug to see if it's worn out.
2. Check the spark plug for electrode erosion and excessive carbon or other deposits, and replace it if necessary.
3. Measure the spark plug gap with a wire thickness gauge and, if necessary, adjust the gap to specification.

### To install the spark plug

1. Clean the surface of the spark plug gasket and its mating surface, and then wipe off any grime from the spark plug threads.
2. Install the spark plug with the spark plug wrench by turning it clockwise, to the specified torque.
3. Install the spark plug cap.

OEM manufacturer specified spark plug is either, NST/ A7RTC or NGK / CR6HSA.

4. Tightening torque: Spark plug:

12 N•m (1.2 kgf•m, 8.7 lb•ft)

Spark Plug Gap:

0.06~0.085mm (0.024-0.028 in)

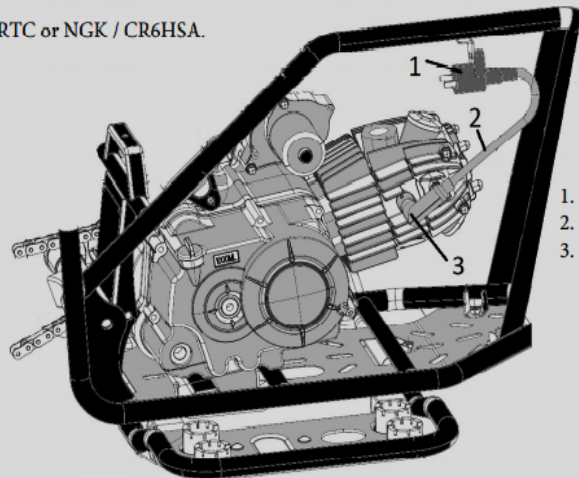
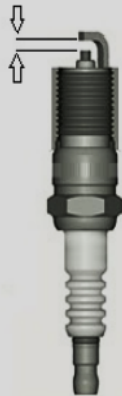

1. Ignition Coil
2. Coil Wire
3. Spark Plug Cap

## Drive Chain

### Checking Drive Chain Slack

The drive chain slack should be checked before each ride.

How to check for drive chain slack;

1. Place the ATV on a level surface.
2. Move the ATV back and forth to locate the tightest portion of the drive chain, and then measure the drive chain slack as shown.
3. If the drive chain slack is incorrect, adjust chain before riding ATV.

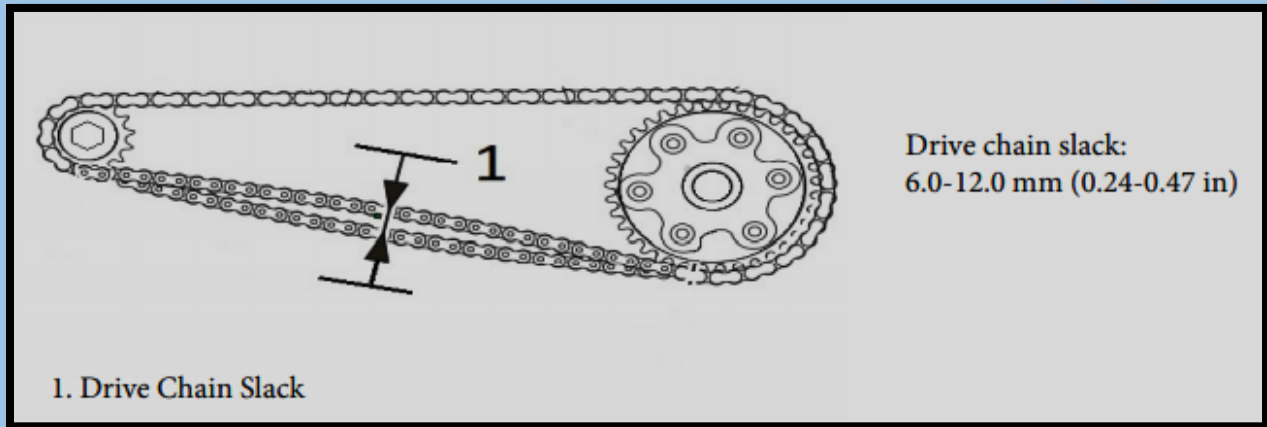

### NOTICE

**NOTICE:** Improper drive chain slack will overload the engine as well as other parts of the ATV. To prevent this from occurring, keep the drive chain slack within the specified limits.

### TIP

when checking and adjusting drive chain slack, always check without any weight on vehicle and all tires are on even surface area.

### TIP

Always use high quality all-condition lube that is compatible with all O-ring and non-O-ring chains.

## Adjust Drive Chain

To adjust the drive chain slack

1. Loosen axle carrier/housing bolts.
2. For all Tao Motor models equipped with chain tensioner, always do the following; lift and hold the chain tensioner off the chain to release chain tension until the chain adjustment is completed.

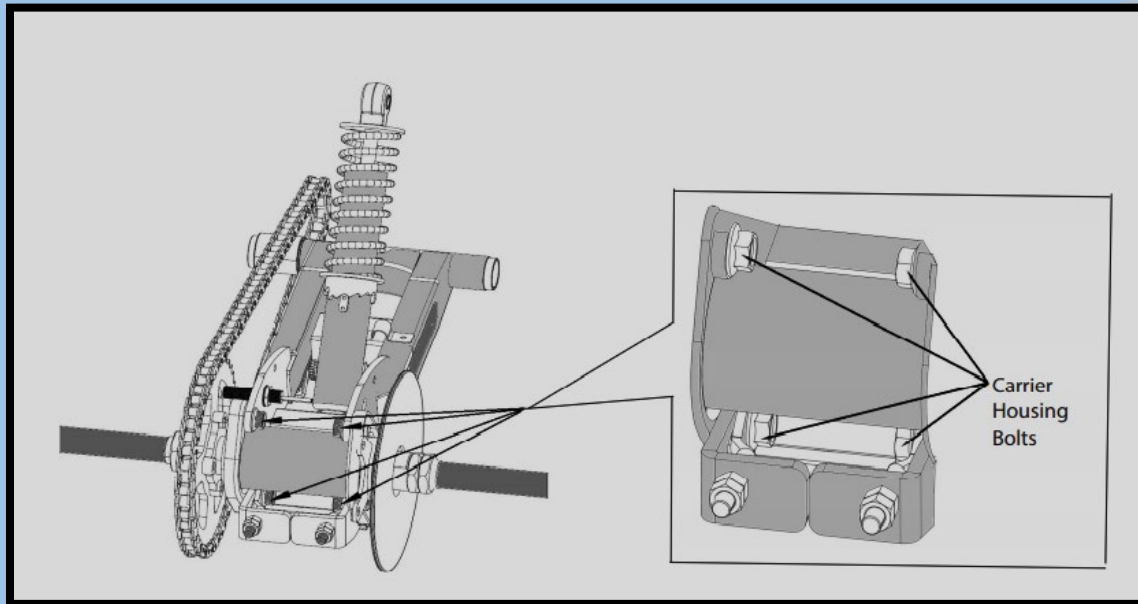

To tighten drive chain,

1. Loosen the chain adjuster nut (#1) on the back side of the carrier/housing.
2. Tighten the chain adjuster nuts (#2) to move the carrier/housing forward.
3. When proper chain slack is achieved tighten chain adjuster nuts (#1,3).

To loosen drive chain,

1. Loosen the chain adjuster nut (#1) on the back side of the carrier/housing tap.
2. Loosen the chain adjuster nuts (#2,3).
3. Tighten the chain adjuster nuts (#1) on the back side of the carrier/housing tap. To move the carrier/housing rearward.
4. When proper chain slack is achieved tighten chain adjuster nuts (#2,3).

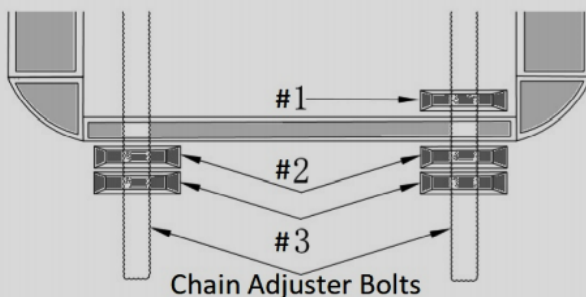

Drive chain slack:  
6.0-12.0 mm (0.24-0.47 in)

Tightening Torques:  
14 Nm / 10 ft/lbs Chain Adjuster Nuts (#1,2,3)  
45 Nm / 33 ft/lbs Carrier/Housing Bolts

3. Tighten carrier housing bolts.

#### Cleaning/Lubricating Drive Chain

The drive chain must be cleaned and lubricated at the intervals specified in the periodic maintenance and lubrication chart, otherwise it will quickly wear out, especially when riding in dusty or wet areas. Service the drive chain as follows.

1. Remove all dirt and mud from the drive chain with a brush or cloth.
2. Spray chain lubricant on the entire chain, making sure that all side plates and rollers have been sufficiently oiled.

#### NOTICE

The drive chain must be lubricated after washing the ATV or riding in the rain or wet areas.

Veloz PowerSports Inc.

## Parking Brake

Use the parking brake before starting the engine or after parking the ATV, **especially** on a slope. This ATV is equipped with a front axle parking brake.

Front Axle Parking Brake: Apply the front brake lever and push down the lock button to apply the parking brake. Squeeze the front brake lever to release the parking brake.

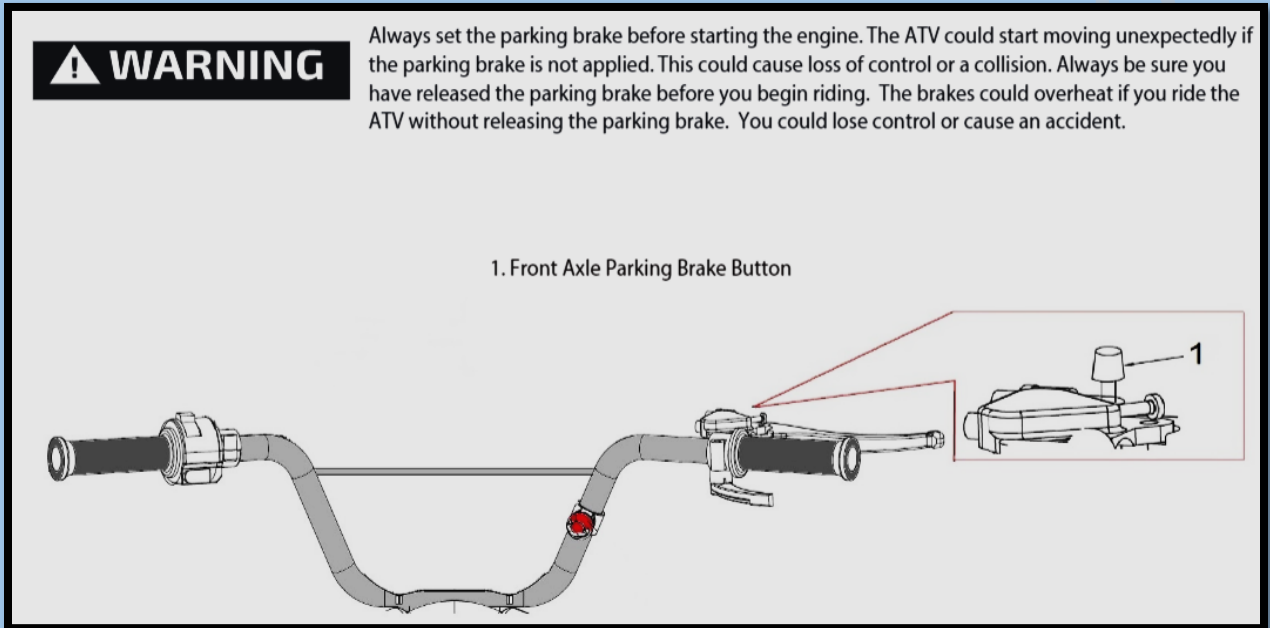

## Engine Stop Lanyard Cord and Remote

The D125, T125 has two emergency-stop engine switches. The primary emergency engine shut off switch is the lanyard cord and the secondary is the wireless engine shut off key fob.

### **⚠ WARNING**

The wireless engine shut off key fob has a limited range that varies in different conditions. **DO NOT RELY** solely on the key fob as the emergency engine shut off switch, especially during operator training.

#### KEY FOB:

The wireless engine shut-off is desired for use by an adult supervising the child operating the ATV. The wireless engine shut-off will work in the range of 50ft. If outside the range of the remote the remote will not stop the engine.

1. Test the range by turning on the ATV and walk 50 feet away and press the shut-off button on the wireless remote. The engine should stop running, if the engine continues to run, you may need to get closer or make sure there are no obstructions between the ATV and you.
2. Before using the wireless engine shut-off switch make sure the batteries in the remote are new and have a full charge. Low or dead batteries in the wireless remote can prevent it from working properly.
3. The wireless engine shut-off key fob should not be used as a full-time engine stop switch by the operator.

### **TIP**

Supervising adults can use the wireless engine shut-off switch to turn the engine off if the operator is riding recklessly or beyond his or her skill level. Once corrective instructions have been given, the adult can restart the engine using the wireless remote switch.

The lanyard cord is designed for use by an adult supervising the child operating the ATV. When using the engine stop switch cord, be sure the speed limiter on the handlebar is adjusted and the engine speed limits the ATV to a walking speed.

1. Install the cap on the end of the engine stop switch cord onto the engine shut-off switch (Red button).
2. Put your fingers in the loop at the other end of the cord.
3. As your child is riding, walk behind the ATV, closely watching his or her actions as well as the path ahead.
4. If there is a potential hazard ahead or if your child is not riding correctly, pull firmly on the cord (lanyard) to stop the engine. Because the ATV will continue to roll for some distance, allow extra time and distance to pull the cord before a potentially hazardous situation might be encountered.

### **NOTICE**

**The ATV will not start without the cap in place.**

### **TIP**

The lanyard assembly can be attached on the left or right side of the handlebar.

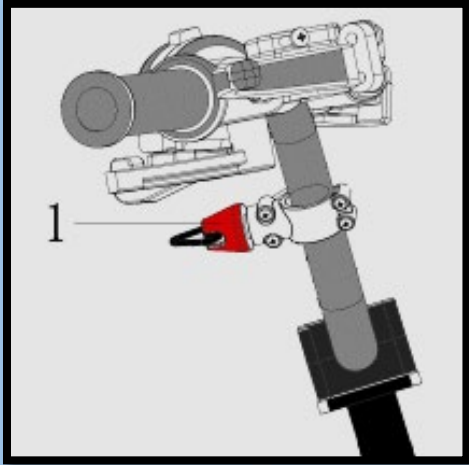
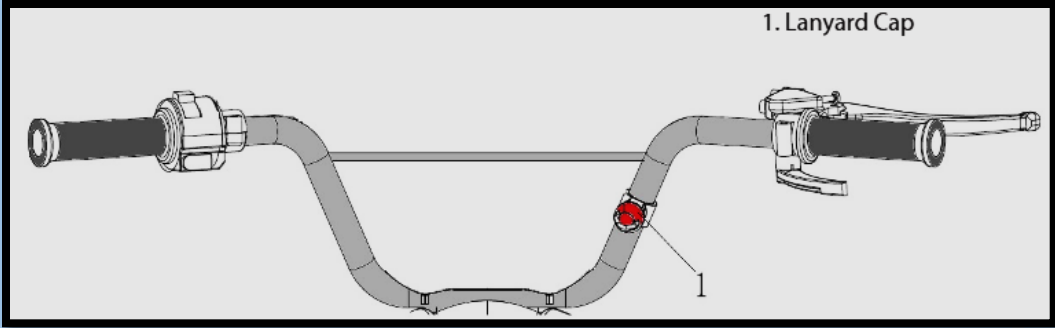

## Control Layout

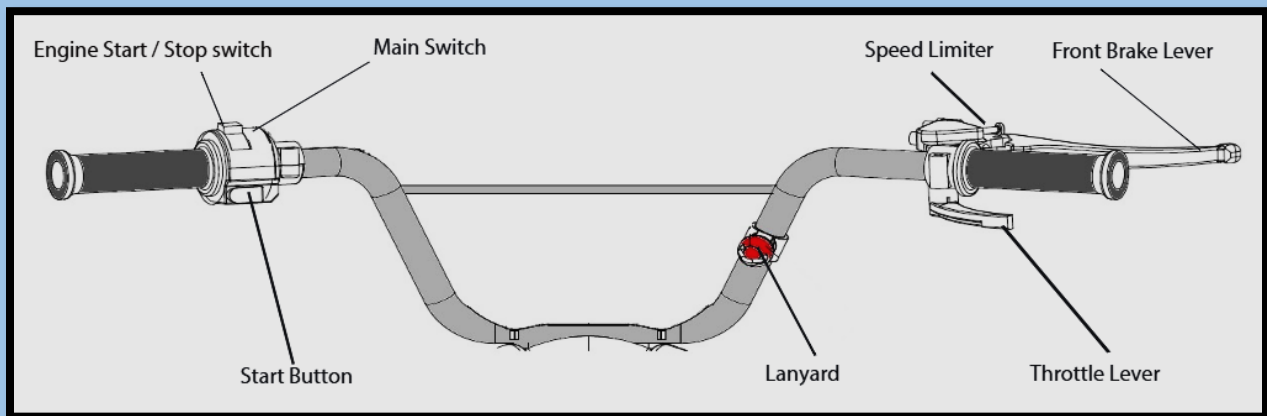

### CONTROLS & FUNCTIONS

#### IGNITION SWITCH

The positions of the ignition switch are as follows.

**Ignition ON** All electrical systems are supplied with power, and the engine can be started.

The key cannot be removed.

**Ignition OFF** All electrical systems are off. The key can be removed.

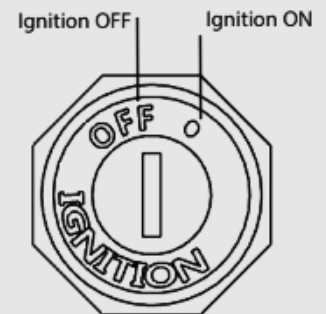

## MAIN SWITCH

### Engine Start/Stop switch



Use this switch to "Stop" the engine in an emergency situation. The engine will not start when this switch is set to this position.



Set this switch to "Run" position before starting the engine.

### START BUTTON

Push start button to crank the engine with starter.

See the starting instructions on page 21 before starting the engine.

1. Engine Run
2. Engine Stop
3. Start Button

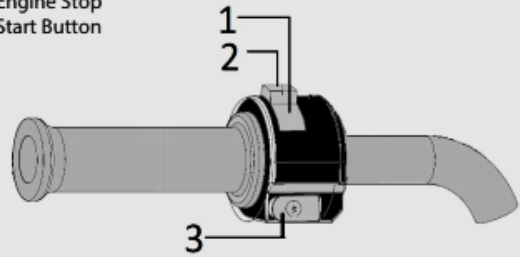

## NOTICE

### ENGINE STOP SWITCH WITH LANYARD

Lanyard cap must be pushed in all the way for the engine to start.

### DAYTIME RUNNING LIGHT

This Boulder B1/ B110 ATV is equipped with day time running light only . This ATV is not intended for night time riding.



## WARNING

This ATV is not intended for night time riding . The lights on this vehicle are daytime running lights only.

### THROTTLE

Once the engine is running, push the throttle lever to increase the engine speed. Regulate the speed of the ATV by varying the throttle position. The throttle lever is spring-loaded to return to the start position when let go. Before starting the engine, make sure the throttle lever is smooth in operation and will return to the start position. If throttle lever is not smooth in operation or will not return to start position do not start engine.

## Speed Limiter



The Boulder B1/ B110 ATV is equipped with a vehicle speed limiter adjusting screw. Beginning riders should start with slowest setting to learn how to control this vehicle. Once the operator has demonstrated mastery of the ATV, the supervising adult can adjust speed limiter screw to increase the top speed . The vehicle speed limiter keeps the throttle from fully opening, even when the throttle lever is pushed to the maximum. The adjusting screw may be gradually turned out as the beginner becomes more familiar with operating this ATV.

## NOTICE

The adjustable speed limiter screw must be installed for operation. Failure to install a speed limiter screw may result in water or dirt ingestion and potential damage to the vehicle.

### SPEED LIMITER ADJUSTMENT



## WARNING

Adults should always limit maximum restricted speed within the ability and capacity of the child to operate the ATV safely. Never allow the child to adjust the speed limiter screw.

### To increase top speed

1. Loosen locknut (#1).
2. To increase the top speed of the ATV turn the adjustment screw counter clockwise. (#2).
3. Tighten the locknut to set adjustment screw in desired position(#1).

### To decrease top speed

1. Loosen locknut (#1).
2. To decrease the top speed of the ATV turn the adjustment screw clockwise. (#2).
3. Tighten the locknut to set adjustment screw in desired position(#1).

### FRONT BRAKE LEVER

The front brake lever is located on the right handlebar. To apply the front brake, pull the brake lever toward the handlebar grip.

### REAR FOOT BRAKE LEVER

The rear foot brake lever is located on the right foot rest . To apply the rear brake, push the brake with your right foot toward the ground.

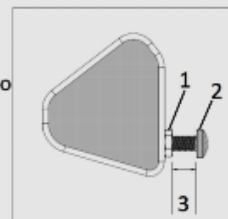

1. Locknut
2. Adjustment Screw
3. Adjustment Range

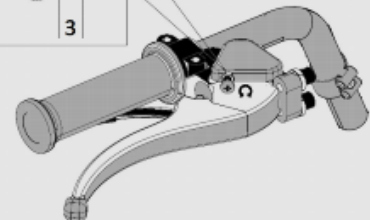

## Choke Lever

Starting a cold engine requires a richer air-fuel mixture. Move the choke lever all the way up when starting a cold engine. Once the engine is warmed up return the choke lever all the way down in the running position.

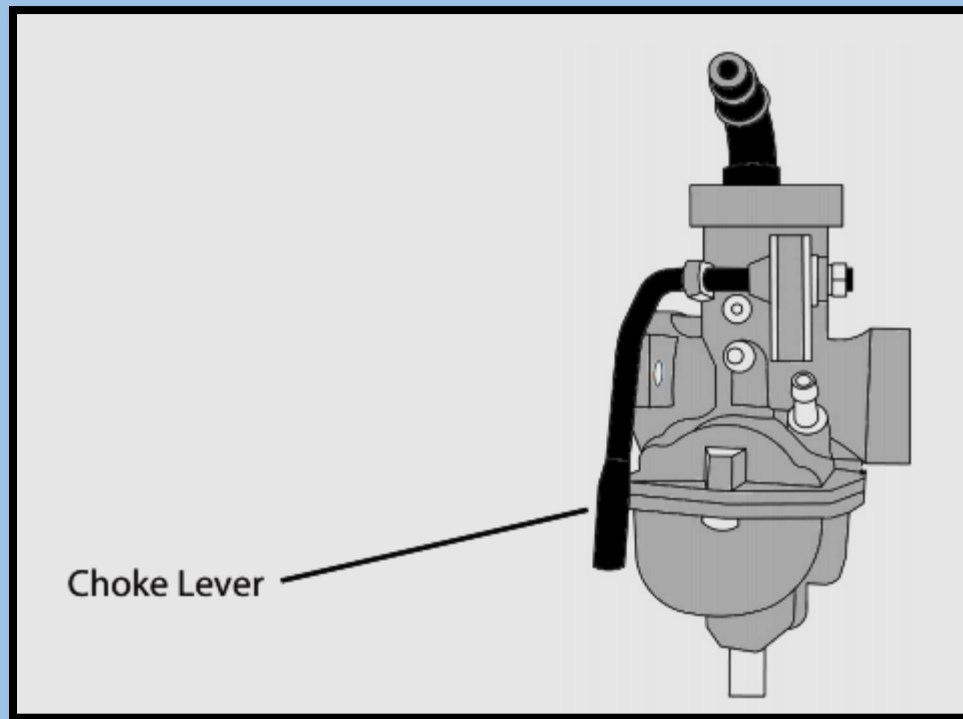

### NOTICE

For maximum engine life, never accelerate hard when the engine is cold or choke lever is in the on position.

## Fuel Tank Capacity

### **⚠ WARNING**

Gasoline and gasoline vapors are extremely flammable. To avoid fires, explosions and to reduce the risk of injury when refueling, follow these instructions.



1. Before refueling, turn off the engine and be sure that no one is sitting on the vehicle. Never refuel while smoking or while in the vicinity of sparks, open flame, or other sources of ignition such as the pilot light of water heaters and clothes dryers.
2. Do not overfill the fuel tank. When refueling, be sure to insert the pump nozzle into the fuel tank filler hole. Stop filling when the fuel reaches the bottom of the filler tub. Because fuel expands when it heats up, outside heat can cause fuel to expand and overflow fuel tank.

### **⚠ WARNING**

If any fuel spills during fueling please wipe quickly, fuel may deteriorate plastic body.

### **⚠ WARNING**

Remove the fuel tank cap by turning it counter clockwise.  
Turn the fuel tank cap fully clockwise to make sure it is securely closed

Your ATV's engine has been designed to use regular unleaded gasoline with a pump octane number of 91 or higher.

Using Ethanol-added fuel may lead to carburetor clogging due to the fuel's sulfuric content reacting with brass and aluminum components in the fuel system. Tao Motor always recommends using a fuel stabilizer to help mitigate damaging corrosion. Visit your dealer to purchase recommended stabilizers and lubricants.

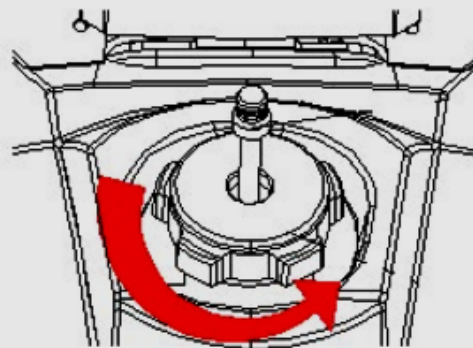

## Fuel Cock/ Fuel Valve

### FUEL COCK/ FUEL VALVE

The fuel cock/valve supplies fuel from the tank to the carburetor.  
The fuel cock/valve lever positions are explained as follows and shown in the illustrations.

#### FUEL OFF

Arrow mark positioned over "OFF" position. Fuel is off and fuel will not flow to the carburetor. Always turn the fuel valve to the "OFF" position and allow the engine to idle until it burns remaining fuel in the line when the ATV is being stored. Once the fuel in the line has been cleared, drain the carburetor bowls. Following this procedure will help reduce corrosion and carburetor damage.

#### FUEL ON

Arrow mark positioned over "On" position. Fuel is on and fuel will flow to the carburetor.

#### STORAGE

Drain gasoline from the fuel tank and carburetor of the ATV if being stored for more than over 48hrs.



## Tires

Check tire pressure with tire gauge to make sure that both front tires and rear tires are equally inflated and meet the recommended PSI specifications. All Tao Motor ATVs are installed with tubeless, lower-pressure ATV valved tires.

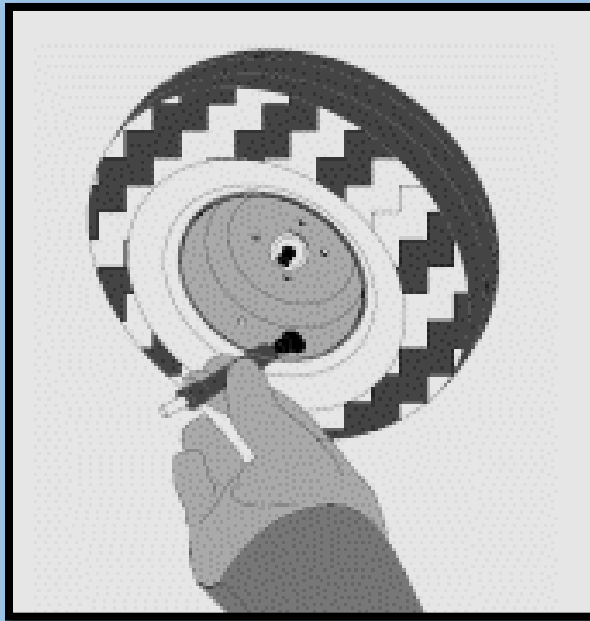

## Tire Wear Limit

When the tire groove decreases to 3mm (0.12 in) due to wear, replace the tire. Never operate an ATV with worn tires, as this may cause loss of control, increasing your risk of an accident or death.

When the tire groove decreases to 3mm (0.12 in) due to wear, replace the tire. Never operate an ATV with worn tires, as this may cause loss of control, increasing your risk of an accident or death.

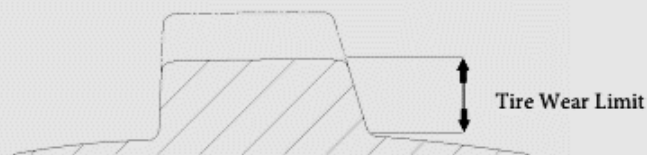

## Starting Engine (Warm vs. Cold)

### STARTING ENGINE (COLD)

1. Set the parking brake. (The engine can be started only when the rear front/rear brake lever is applied.)
2. Turn the fuel valve lever to the "ON" position.
3. Turn the ignition key to the "ON" position.
4. Set "RUN" position on main switch.
5. Set gear box to neutral position. The neutral position light will illuminate on instrument cluster.
6. Set the choke lever to cold start position (all the way up).
7. Press and hold the start button until the engine starts. Never hold the start button for more than 10 seconds per try. It may be necessary to push the throttle lever a small amount to start the engine.
8. When engine warms up, move the choke lever down. Choke lever must be in the off position (all the way to the down) in order to operate the ATV.
9. Release the parking brake.

### STARTING ENGINE (WARM)

1. Set the parking brake. (The engine can be started only when the rear front/rear brake lever is applied).
2. Turn the fuel valve lever to the "ON" position.
3. Turn the ignition key to the "ON" position.
4. Set "RUN" position on main switch.
5. Set gear box to neutral position. The neutral position light will illuminate on instrument cluster.
6. Set the choke lever to warm start position (all the way to down).
7. Press and hold the start button until the engine starts. Never hold the start button more than 10 seconds per try. It may be necessary to push the throttle lever a small amount to start the engine.
8. Release the parking brake.

21

## Breaking in the Engine

### ENGINE BREAK-IN

Proper engine break-in will increase the lifespan of your Tao Motor vehicle ATV. The engine break-in period is the initial 20 hours of operation. You should avoid maintaining a constant engine RPM and do not operate your ATV above 1/2 throttle during the break-in period. Do not operate your ATV at full throttle during the break-in period.

#### NOTICE

First service, including the break-in service work should be performed at 10 hours. The second service should be performed at the end of the 20-hour break-in period. Subsequent service work should be performed after every 20 hours of operation.

#### HOT MUFFLER & ENGINE

The muffler and other engine parts become extremely hot during operation and remain hot after the engine has stopped. To reduce the risk of fire during operation or after leaving the ATV, do not let brush, grass and other materials collect under the vehicle, near the muffler or exhaust pipe, or next to other hot parts. Check under the vehicle after operating in areas where combustible materials may have collected. Do not run the vehicle in idle or after running by parking in long dry grass or other dry combustible organic materials.

To prevent burns, avoid touching the exhaust system. Park the ATV in a place where pedestrians or children are not likely to touch it.

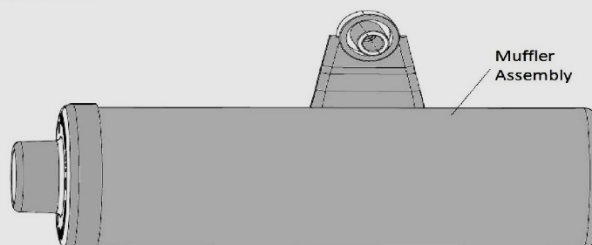

22

## Parking

When parking the ATV: first apply the brake lever, stop the engine, apply the parking brake, and then turn the fuel valve to “OFF” position. Never park the ATV on hills that are too steep to walk up easily.

## Accessories and Modifications

Any modifications made to your vehicle’s design or operation can put you and others at great risk of serious injury or death. Never install accessories that would impair the performance/function of your ATV. Carefully inspect the accessory before using it to make sure that it does not in any way reduce ground clearance, limit suspension travel, steering travel, or control operation.

Use caution when adding any electrical accessories or change the normal operation of the vehicle. If electrical accessories exceed the capacity of the ATV’s electrical system, could result in a dangerous situation and possible loss of power or damage the engine.

Installing aftermarket parts, and/or accessories could void your Tao Motor Factory warranty. See a Tao Motor dealer for more details.

## Rear Cargo Rack

Rear cargo rack can carry a maximum of 11 lbs. and should never be overloaded. Use caution when loading the cargo rack and Make sure cargo is secured with tie downs to prevent load shift.

### **NOTICE**

Overloading your Boulder B1/ B110 could cause a lack of control resulting in severe injury or death.

## Gear Selector Lever

### GEAR SELECTOR LEVER

This ATV is equipped with a 2 gear transmission gearbox, The gear shift lever is located on the left side of the ATV. When changing the transmission position, first apply the brakes to come to a complete stop, before moving the lever to the desired position.

To Engage Forward Gear: Push forward on gear shifter lever, once the gear engages, release the shifter lever and it will return the center position.

To Engage Reverse Gear: Pull back on gear shifter lever until the shifter engages, then release the shifter and allow the shifter to return to the center position.

When "D" is displayed on the instrument panel the forward gear is engaged.

When "R" is displayed on the instrument panel the reverse gear is engaged.

When "N" is displayed on the instrument panel the neutral gear is engaged.

#### **⚠ WARNING**

Always look behind the vehicle prior to shifting in reverse to be clear of any obstacles, animals or people. Remain seated all times, do not stand up.

#### **NOTICE**

Always completely stop the ATV and apply the brakes prior to moving the transmission lever.

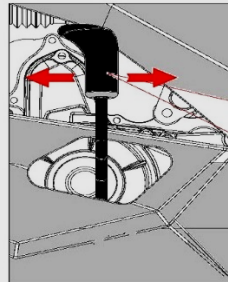

D-N-R

Care should be used when riding on loose or slippery surfaces since the ATV may slide. Unexpected or uncorrected sliding can lead to an accident. You reduce the tendency of front wheel sliding by positioning your body weight forward towards the front of the vehicle while remaining seated.

If your rear wheels start to slide in a sideways motion, you may be able to regain control by steering in the opposite direction. Applying the brakes quickly or accelerating when sliding out of control is not recommended until you have corrected the slide.

24

## Throttle Cable

### THROTTLE CABLE

Throttle cable inspection

Inspect throttle cable for excessive wear, kinking or fraying. Ensure cable moves freely.

#### **NOTE**

The throttle cable must be replaced if any signs of wear, fraying or other damages found.

### THROTTLE CABLE ADJUSTMENT

Check throttle lever free-play, adjust if necessary.

#### **NOTE**

Please check with Tao Motor dealer if throttle cable adjustment can not be adjusted properly.

Normal throttle free-play is 5mm to 10mm 0.197 In to 0.394

#### **TIP**

Lubricate cable using silicone cable lubricant to reduce premature wear and to ensure proper movement of the cable.

To adjust cable,

1. Pull rubber dust covers back to inspect and adjust throttle cable.
2. Loosen lock nut.
3. Turn throttle cable adjuster to make proper adjustments of throttle cable.
4. Tighten locking nut and reinstall rubber dust cable covers.

#### **NOTE**

Measure throttle free play at the tip of the lever.

Check proper throttle cable adjustment by turning handlebars completely to the left and right. If RPM increases when turning, then re-adjust throttle cable to increase lever free-play. Check throttle cable routing to make sure there is no cable binding when turning handlebars.

#### **NOTE**

The handlebar should move left to right without change in engine RPM.

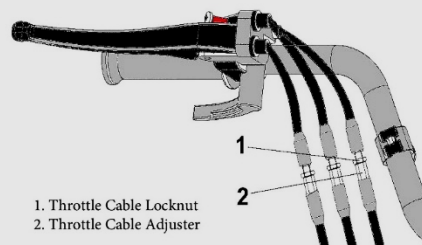

1. Throttle Cable Locknut
2. Throttle Cable Adjuster

25

## Front Brake Lever

### FRONT BRAKE LEVER

Recommended brake service by certified Tao Motor technician. See your Tao Motor Dealer for details.

**⚠ WARNING** Operating with improperly adjusted brakes could lead to a loss in braking ability and or cause an accident. Brakes can become very hot during prolonged braking or use. Never touch brakes until they are cool.

How to adjust front brake lever free-play.

The front brake lever freeplay must be checked and if necessary adjusted at the intervals specified in the periodic maintenance and lubrication chart. The brake lever freeplay should measure 9.3-13.3 mm (0.37-0.52 in) as shown.

How to adjust brake lever freeplay upper

1. Loosen the locknut's (#2)
2. Adjusting bolt's (#1).
3. Adjusting bolt's (#1) in direction (a) to increase the lever freeplay, and in direction (b) to decrease it.
4. Tighten the locknut's(#2).
5. While applying the front brake the upper and lower cable lengths should be equal .
6. The cable joint(#4) will become vertical.

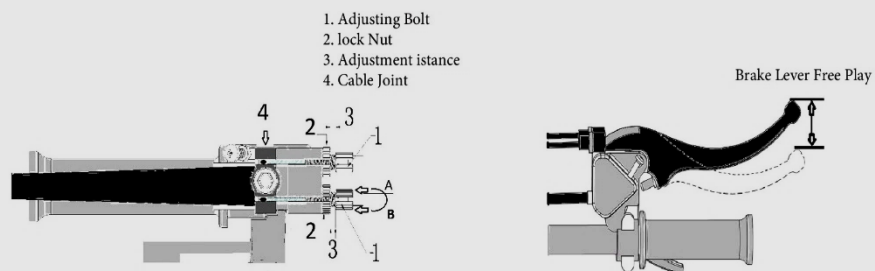

26

## Front Brake Lever Adjustment

### FRONT BRAKE LEVER FREEPLAY LOWER ADJUSTMENT

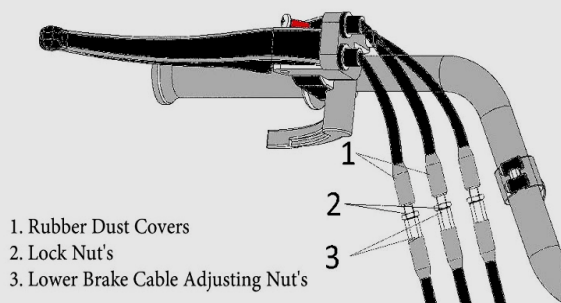

If the upper brake cable adjuster is threaded out to it's near limits, or the correct freeplay cannot be obtained, attempt to adjustment with the lower cable adjustment.

1. Pull back the rubber dust covers.
2. loosen the lock nut's.
3. Turn the lower adjusting nut's and check lever free play.
4. Tighten lock nut's.
5. Install rubber dust cover.

Make sure both brake cables are adjusted evenly.

## Hydraulic Rear Brake

### FRONT BRAKE LEVER FREEPLAY LOWER ADJUSTMENT

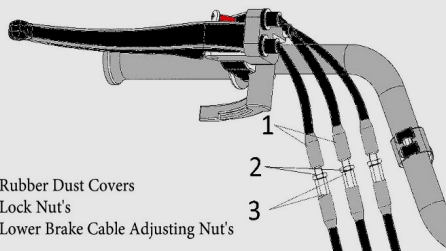

1. Rubber Dust Covers
2. Lock Nut's
3. Lower Brake Cable Adjusting Nut's

If the upper brake cable adjuster is threaded out to it's near limits, or the correct freeplay cannot be obtained, attempt to adjustment with the lower cable adjustment.

1. Pull back the rubber dust covers.
  2. loosen the lock nut's.
  3. Turn the lower adjusting nut's and check lever free play.
  4. Tighten lock nut's.
  5. Install rubber dust cover.
- Make sure both brake cables are adjusted evenly.

### HYDRAULIC REAR BRAKE

#### ⚠ WARNING

New brakes will not perform to their maximum efficiency until after their initial brake-in is complete. Use extra caution.

#### ⚠ WARNING

Brake fluid replacement or brake system maintenance and repairs should be performed by an authorized Tao Motor dealer.

#### NOTICE

The brakes can be very hot after prolong use of the vehicle and can cause burns. Wait for the brakes to cool down.

The rear brake system is a hydraulic type and no adjustment is required. Use the following checklist before each use to maintain the brake system in good operation condition;

- Brake Fluid level
- Brake system for fluid leaks
- Brake cleanliness
- Brake disk for excessive wear and surface condition.
- Brake pads for wear, damage or looseness.

27

#### NOTICE

Have your local Tao Motor dealer inspect brakes system for wear or damage. Always contact your local Tao Motor Dealer if you have any concerns after inspecting your brake system for wear or damage.

#### Recommended Brake Fluid

Always use brake fluid type DOT 3 or 4.

#### Brake Fluid Level

Always check for the proper brake fluid reservoir level as follows;

Brake fluid reservoir is located on the frame in front of the right rear tire . With the ATV on a level surface, check brake fluid in reservoir for proper level. The fluid should above the MIN mark. Add fluid as required, but never overfill and clean filler cap before removing.

#### NOTICE

The Reservoir is full when the fluid reaches the top of the window.  
A low fluid level may indicate leaks or worn brake pads.

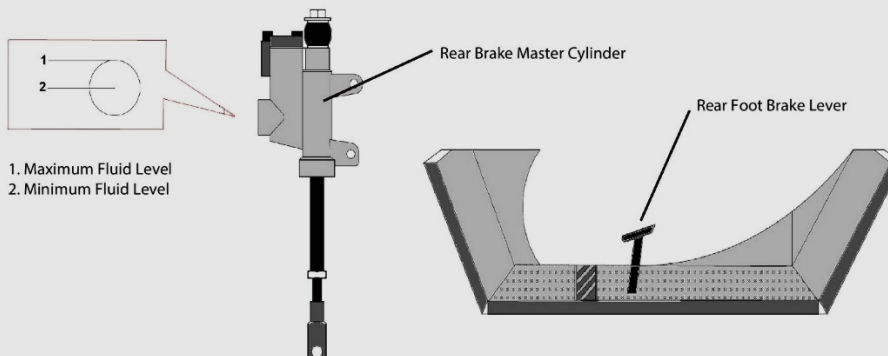

1. Maximum Fluid Level
2. Minimum Fluid Level

28

## Engine Idle Adjustment

### ENGINE IDLE ADJUSTMENT

If it is necessary to adjust the carburetor idle screw due to changed outside environmental conditions, to adjust carburetor idle screw as follows;

1. Apply parking brake.
2. Warm up the engine by running the vehicle.
3. Adjust the carburetor idle screw until the desired idle RPM is reached. Turning the idle screw in (clockwise) to raise RPM. Turning the screw out (counterclockwise) will lower RPM.
4. The standard idle RPM is  $1500 \pm 150$ .

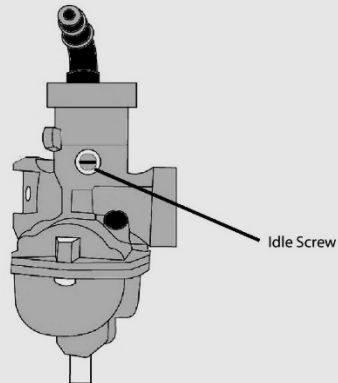

29

## Adjusting Suspension Spring Preload

### ADJUSTING SUSPENSION SPRING PRELOAD

This ATV is equipped with adjustable coil springs front and rear. The spring preload can be adjusted to suit the rider's weight and the riding conditions. Turn the spring preload adjusting ring to increase (stiffest= 5) or decrease (softest= 1) the spring preload. Increased spring tension will stiffen the ride. Decreasing spring tension will soften the ride.

#### NOTICE

The suspension was pre-set at the factory, but can be adjusted with a special suspension adjustment tool available for purchase at your Tao Motor dealer.

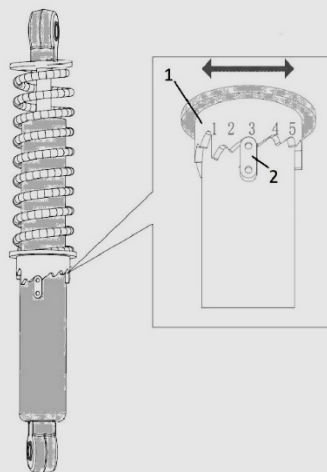

1. Spring Preload Adjustment Ring
2. Position Indicator

#### NOTICE

Never turn the adjusting mechanism beyond the minimum and maximum setting.

30

